

PicoVNA™ 106

6 GHz vector network analyzer

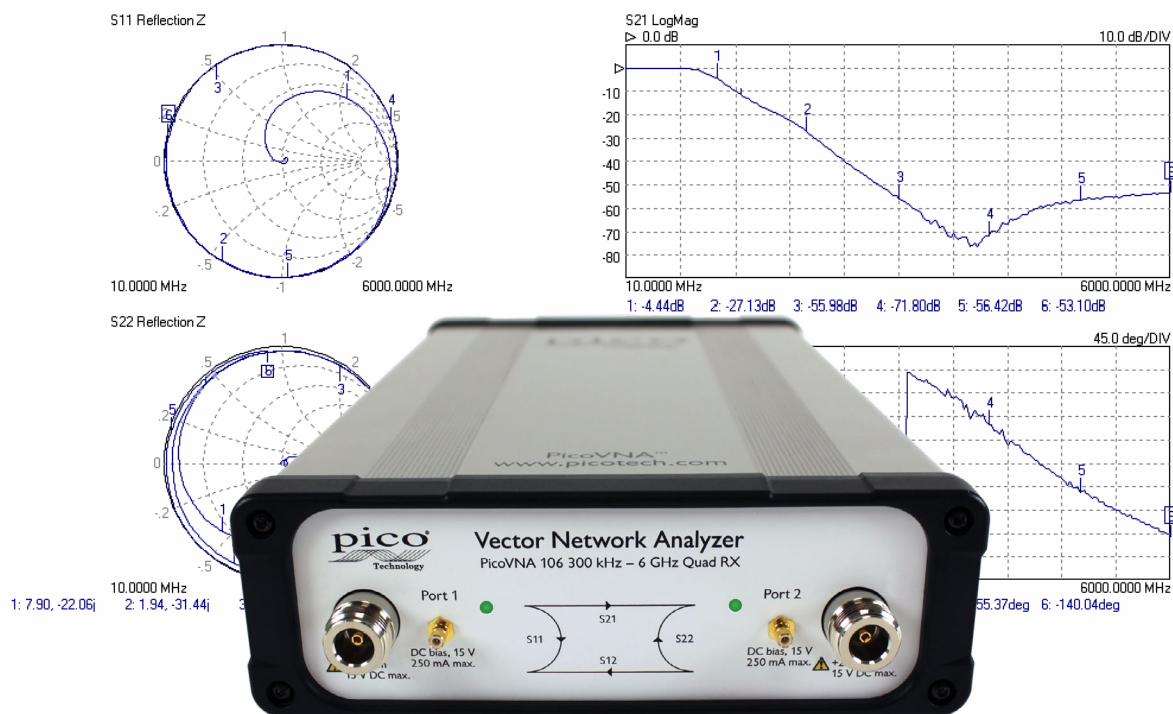

Professional and portable performance at low cost

- 300 kHz to 6 GHz operation
- High speed of > 5000 dual port S-parameters per second
- Quad RX four-receiver architecture for best accuracy
- 118 dB dynamic range at 10 Hz bandwidth
- 0.005 dB RMS trace noise at maximum bandwidth of 140 kHz
- Half-rack, small-footprint, lightweight package

- PC-controlled over USB from a Microsoft Windows interface
- Reference plane offsetting and de-embedding
- Time domain and port impedance transformations
- Tabular and graphic print and save formats, including Touchstone P1dB, AM to PM, and stand-alone signal generator utilities

- Fully accessible, guided 8 and 12-term calibration processes
- 6 calibration modes, including unknown through and connected DUT isolation

Vector network analysis for the many

Once the domain of an elite few, microwave measurement has encroached into the lives of scientists, educators, surveyors, inspectors, engineers and technicians alike. Today's microwave measurements need to be straightforward, portable, accurate, cost-effective and easy to learn.

The PicoVNA 106 is an all new, UK-designed, professional USB-controlled, laboratory grade vector network instrument of unprecedented performance, portability and value for money. Despite its simple outline, small footprint and low cost, the instrument boasts a four-receiver architecture to minimize the uncorrectable errors, delays and unreliability of internal transfer switches.

Despite its small size, the PicoVNA 106 delivers an exceptional dynamic range of 118 dB at 10 Hz and only 0.005 dB RMS trace noise at its maximum operating bandwidth of 140 kHz. It can also gather all four S-parameters at every frequency point in just 190 μ s; in other words, a 500 point 2-port .s2p Touchstone file in less than a tenth of a second. Its low price means that the PicoVNA 106 would be cost-effective as a deep dynamic range scalar network analyzer or a single-port vector reflectometer. However, despite its size and price, the PicoVNA 106 really is a full-function dual-port, dual-path vector network analyzer. It's affordable in the classroom, in small businesses and even in amateur workshops, yet capable of meeting the needs of all users up to the microwave laboratory technician and expert.



Vector network analysis everywhere

The PicoVNA's small size, weight and cost, and high performance suit it to field service, installation test, embedded and classroom applications. With its remote automation capability, it's also attractive in applications such as:

- Test automation
- Manufacturers needing to integrate a reflectometry or transmission measurement core
- Inspection, test, characterization and calibration in the manufacture, distribution and service center industries
 - Electronics component, assembly and system, and interface/interconnect ATE (cable, PCB and wireless)
 - Material, geological, life science and food sciences; tissue imaging; penetrating scan and radar
- Broadband cable and harness test at manufacture, installation and fault-over-life monitoring
- Antenna matching and tuning

Quad RX four-receiver architecture

In a VNA a swept sine-wave signal source is used to sequentially stimulate the ports of the interconnect or device under test. The amplitude and phase of the resultant transmitted and reflected signals appearing at both VNA ports are then received and measured. To wholly characterize a 2-port device under test (DUT), six pairs of measurements need to be made: the amplitude and phase of the signal that was emitted from both ports, and the amplitude and phase of the signal that was received at both ports for each source. In practice this can be achieved with a reasonable degree of accuracy with a single source, a transfer switch and two receivers; the latter inputs being switched through a further pair of transfer switches. Alternatively three receivers can be used with an additional input transfer switch or, as in the PicoVNA, four receivers can be used. Using four receivers eliminates the receiver input transfer switch errors (chiefly leakage and crosstalk) that cannot be corrected. These residual errors are always present in two- and three-receiver architectures and lead to lower accuracy than that of the *Quad RX* design.

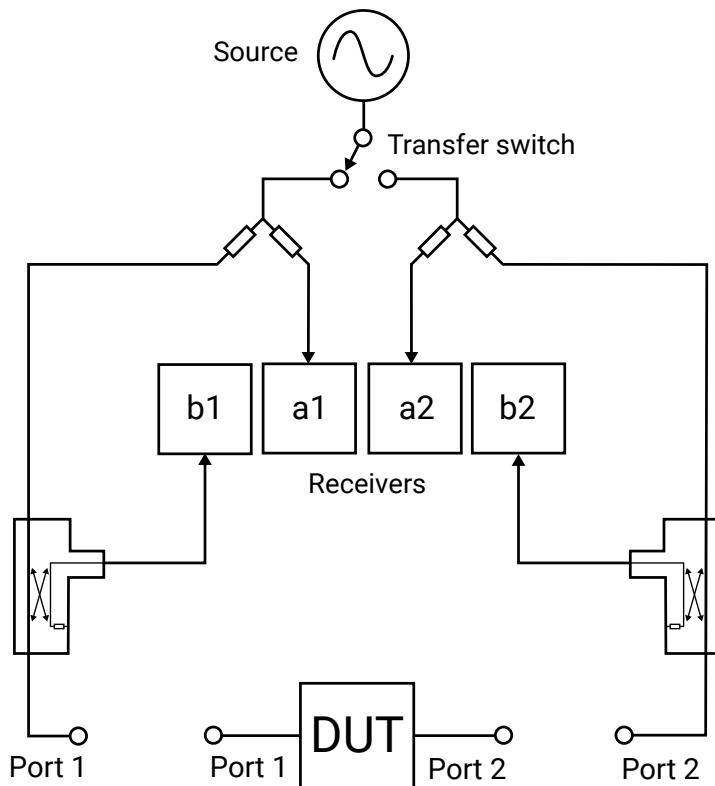

Support for 8 and 12-term calibration and the *unknown through*

Almost all vector network analyzers are calibrated for twelve error sources (six for each signal direction). This is the so-called *12-term calibration*, which experienced VNA users are used to performing fairly regularly. In a four-receiver design some error sources are so reduced that *8-term calibration* becomes possible, along with an important and efficient calibration technique known as the *unknown through*. This gives the ability to use any *through* interconnect (including the DUT) during the calibration process, vastly simplifying the procedure and reducing the number of costly calibration standards that need to be maintained. Advanced vector network analyzer users will be pleased to know that internal a-wave and b-wave data can be exported for diagnostic use. This enables the derivation of transfer switch error terms, amongst others.

Bias-Ts

Bias-Ts are often not provided, or available as costly extras, on other VNAs. Use the PicoVNA 106's built-in bias-Ts to provide a DC bias or test stimulus to active devices without the complexity and cost of external DC-blocks. The bias is supplied from external power supplies or test sources routed to the SMB connectors adjacent to each VNA port.

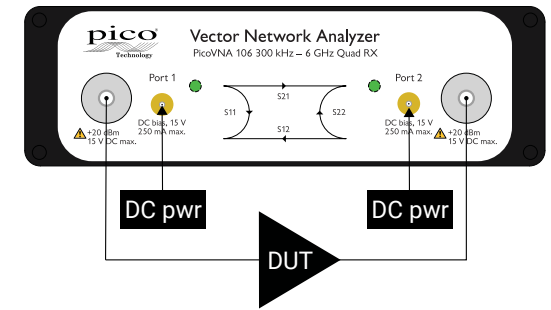

Use bias-Ts to power an active DUT

Other I/O

Power (12 to 15 V DC @ 22 W) and USB 2.0 control are located on the rear panel. Trigger I/O for sweep synchronization and 10 MHz I/O for reference clock synchronization are available on four BNC sockets.

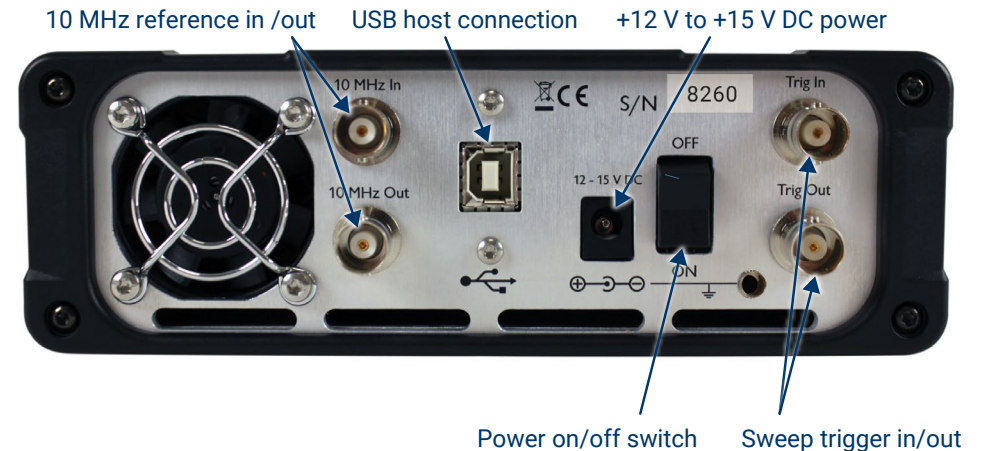

Test cables and calibration standards

A range of RF and Microwave accessories are available from Pico Technology. Test cables and calibration standards have particular significance to the overall performance of a VNA, so we recommend that you select your accessories carefully.







Cables and standards are often the weakest links in a VNA measurement, generally contributing significantly to measurement uncertainty despite their high cost. At the lowest levels of uncertainty, costs can be significant and measurements can be compromised by seemingly quite minor damage or wear. For these reasons, many customers hold both premium-grade items for calibration, reference or measurement standards, and standard-grade items as working or transfer standards and cables. Pico Technology can now offer cost-effective solutions in both grades.

Phase- and amplitude-stable test leads

Two test cable types and grades are recommended and provided by Pico Technology. Both of high quality, with robust and flexible construction and stainless steel connectors, the main difference between them is the stability of their propagation velocity and loss characteristic when flexed; that is, the degree to which a measurement could change when the cables are moved or formed to a new position. Cables are specified in terms of flatness and phase variation at up to 6 GHz when a straight cable is formed as one 360° turn around a 10 cm mandrel.





Order code	Grade	Connectors	Dielectric	Ø over jacket	Impedance (Ω)	Loss (dB) @ 6 GHz	Phase stability @ 6 GHz	Amplitude stability (dB) @ 6 GHz	Length (mm)
TA336	Standard	N(m)–SMA(m)	Low-density PTFE	7.1 mm (0.28")	50	0.7	2°	0.1	600
TA337		N(m)–SMA(f)							
TA338	Premium	N(m)–PC3.5(m)		7.5 mm (0.30")		0.6	0.8°	0.05	
TA339	N(m)–PC3.5(f)								

Test port adaptors

Order code	Name	Grade	Impedance (Ω)	Bandwidth (GHz)	Connector type*
TA342	 ADA-STD-MM	Standard	50	18	SMA(m-m)
TA343	 ADA-STD-FF				SMA(f-f)
TA357	 ADA-STD-FM				SMA(f-m)
TA340	 ADA-PREM-MM	Premium	50	27	PC3.5(m-m)
TA341	 ADA-PREM-FF				PC3.5(f-f)
TA354	 ADA-PREM-FM				PC3.5(f-m)

Calibration and measurement reference standards

Pico Technology also offers two short, open, load and through (SOLT), 4-piece, 5-port calibration kits in both male and female genders. All kits have high-performance tight-tolerance stainless steel interface connectors. Kits are supplied as an assembled five-port “Y” SOLT, either male or female. They can be disassembled for individual usage, or for economical refurbishment should a calibration standard be damaged. Each SOLT is supplied with traceable calibration data linked to the kit serial number and is supplied in a protective carry case. Both the Standard and Premium kits offer exceptional residual directivity for the price. It is this that combines with good uncorrected port match on the PicoVNA 106 to deliver exceptional price-performance. Premium kits are calibrated to reduced uncertainty using TRL (through, reflect, line) intercomparison above 1.5 GHz. Further specifications for the instrument and calibration kits can be found on later pages. We also offer a calibration service for Pico standards only – see [Ordering information](#).

Order code	Name	Grade	Ports	Impedance (Ω)	Bandwidth (GHz)	Connector type*
TA344	 SOLT-STD-M	Standard	5: short, open, load, through	50	6	SMA(m)
TA345	 SOLT-STD-F					SMA(f)
TA346	 SOLT-PREM-M	Premium	5: short, open, load, through	50	6	PC3.5(m)
TA347	 SOLT-PREM-F					PC3.5(f)

* SMA, PC3.5 and K-type/2.92 connectors can all be mated with each other. SMA type has solid dielectric, PC3.5 has air dielectric.

Test cables and calibration standards selection guide

Calibration kits can be purchased as a pair or as a single kit depending on the primary (best uncertainty) measurement application and its DUT interface, and sometimes to meet a secondary purpose with other DUT interfaces. Budget may also be a consideration. Pico Technology provides for all purchase options. You can order any combination of accessories, but to get you started we recommend that you choose one of the following standard configurations.

Configuration 1: universal

For best overall test efficiency and uncertainty in a mix of single- or dual-port test application of both genders, we recommend this dual-port, insertable test lead and calibration standards configuration and the use of additional test port adaptors as necessary. All calibration modes are then available using the test lead ports or adapted test ports.

Primary DUT interface	Test leads required	Cal. kits required	Supported calibration modes		Example DUT
			Single cal. kit	Dual cal. kit	
1: Dual-port female-male or male-female	Male + female: TA336 + TA337 or TA338 + TA339	Male + female: TA344 + TA345 or TA346 + TA347	N/A	All S-parameters, insertable DUT (zero length through calibration). Non-insertable via port adaptors.	Insertable dual port component or device with male and female ports. Use port adaptors for dual-port single-gender DUT.

Configurations 2 to 5: gender-specific and port-number-specific

The following configurations are recommended where there is a focus upon a particular DUT port or measurement arrangement.

Primary DUT interface	Test leads required	Cal. kits required	Supported calibration modes		Example DUT
			Single cal. kit	Dual cal. kit	
2: Single-port female	Male: 1x TA336 or 1x TA338	Female: 1x TA345 or 1x TA347	Single-port reflectometry: S_{11} or S_{22}	N/A	Component port or a device/fascia-mounted input or output port
3: Single-port male	Female: 1x TA337 or 1x TA339	Male: 1x TA344 or 1x TA346	Single-port reflectometry: S_{11} or S_{22}	N/A	Component or cable port
4: Dual-port female	2 x male: 2x TA336 or 2x TA338	Female: 1x TA345 or 1x TA347	S_{21} transmission, $S_{11} + S_{21}$ All S-parameters, non-insertable DUT.	All S-parameters, non-insertable DUT (faster and unknown through calibration process)	Device/fascia-mounted input and output port or other dual-port measurement
5: Dual-port male	2 female: 2x TA337 or 2x TA339	Male: 1x TA344 or 1x TA346	S_{21} , $S_{11} + S_{21}$ All S-parameters, non-insertable DUT	All S-parameters, non-insertable DUT (faster and unknown through calibration process)	Cable

PicoVNA 2 software

PicoVNA 2 presents standard VNA measurement and calibration simply, intuitively and with efficient usage at its heart. The software offers a comprehensive range of measurements and plot formats in its one, two or four user-configurable measurement channels. All the standard vector network analyzer functions can be seen at a glance.

Import / export, help and utilities

Save, recall, print, labels, calibration tools
Signal generator, P1dB and AM to PM utilities

Direct access to channel settings

Click or touch and drag values, scales and markers

Display formats
One, two or four channels

1

1
2

1 2
3 4

Plot formats
Log magnitude
Phase
Smith chart
VSWR
Group delay
Linear magnitude
Real
Imaginary
Time domain
Polar linear

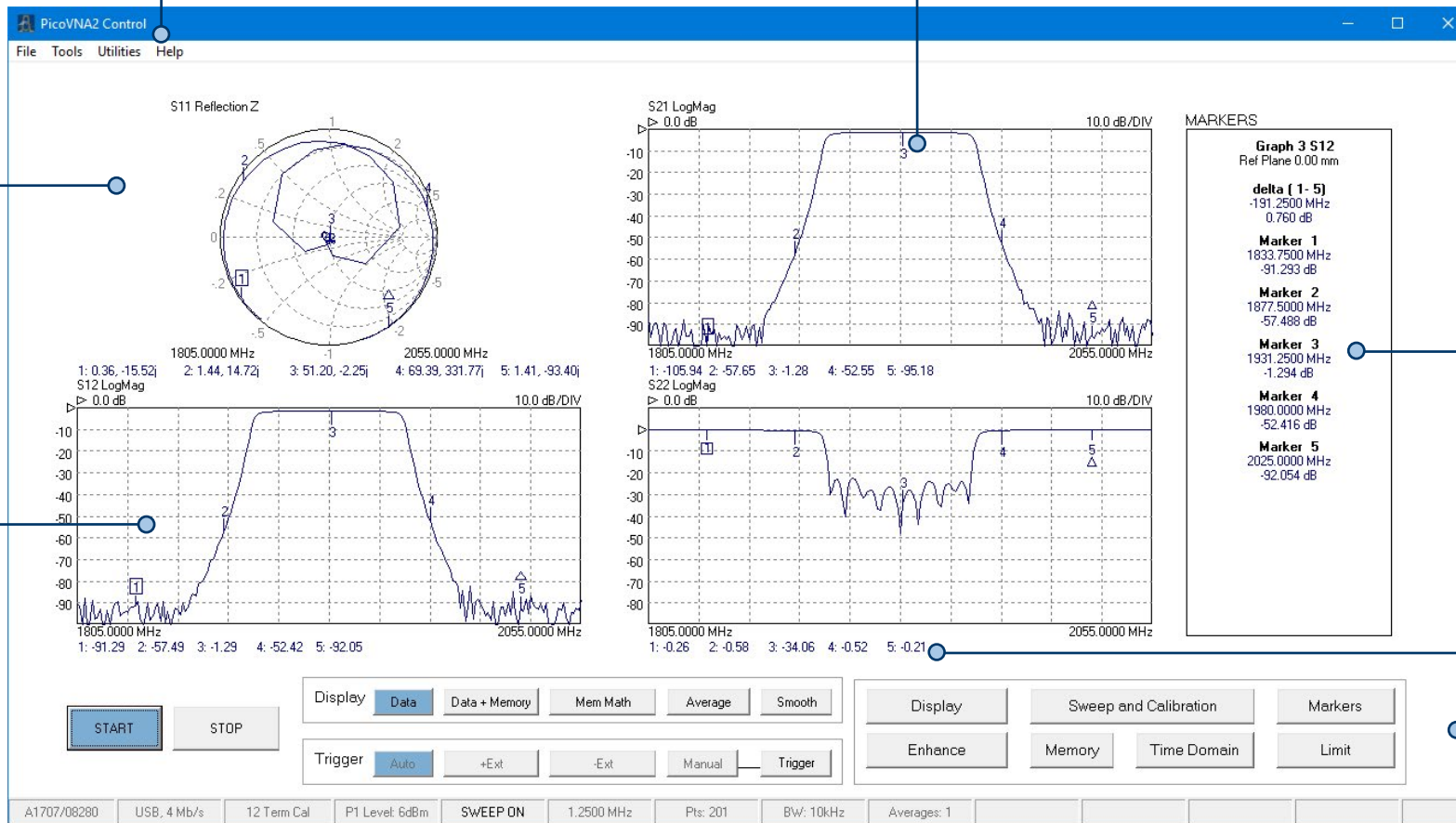

Marker readouts
Table of up to eight markers for the selected channel

Marker summary

User interface
Controls, information and vector trace math functions.

Supported calibrations

The PicoVNA 2 software supports a comprehensive range of calibration modes to address single or dual-port workload with male, female or mixed gender interfaces, all with best achievable accuracy (least uncertainty). In some instances only a single calibration kit may be required, as outlined in the tables above.

As you would expect, the Pico calibration kits are individually serial-numbered and supplied with S-parameter data. This standard-form data is a traceable and accurate record of measured errors for the calibration kit. It can be loaded into the software, which will correct for these errors and those of the instrument during a calibration.

Alternatively, you can use a third-party calibration kit and its data, or you can enter its electrical length, parasitic values and polynomial coefficients into the software if these are supplied rather than a profile data set.

As for any vector network analyzer, for best accuracy a calibration is performed before a measurement with the same sweep span and frequency steps as the measurement. If, however, a change of sweep settings is necessary for a measurement, the PicoVNA 2 software will for convenience interpolate its corrections to the new sweep settings.

An *enhanced isolation* calibration setting is available for optimum dynamic range when using resolution bandwidths below around 1 kHz.

Reference plane extension

Reference plane extension (offset) allows you to shift the measurement reference plane away from the point established during calibration. This is useful in removing the path length of assumed ideal interconnecting, connectors cables or microstrip lines from measurements. PicoVNA 2 software allows independent reference plane extensions on each of the measurement parameters (S_{11} , S_{22} , S_{12} or S_{21}), either as an automatic re-reference or by manual entry. Independent extensions allow, for example, different extensions on the two ports for S_{11} and S_{22} and then through-line normalization for S_{21} and S_{12} transmission comparison with equivalent length through-line.

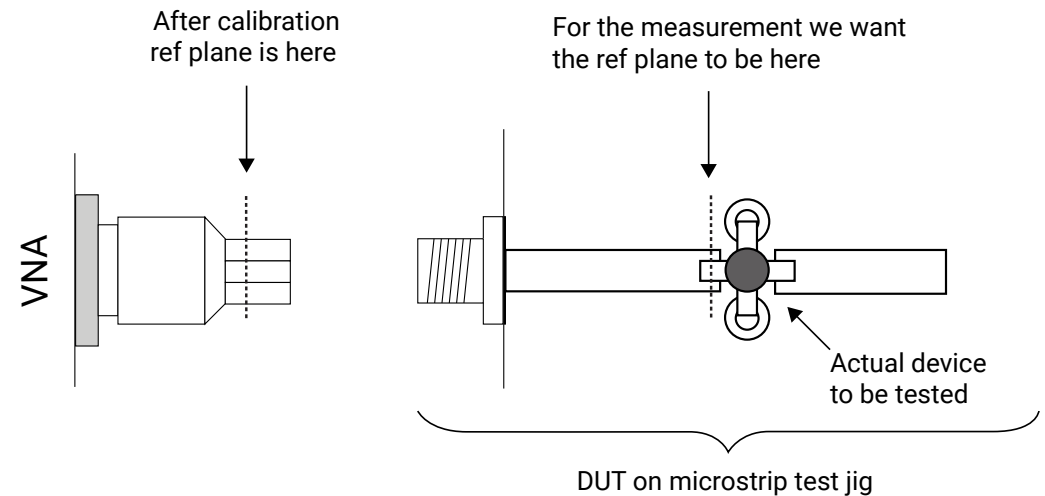

De-embedding embedded port interfaces

When it is unsafe to assume the above ideal interconnecting connectors cables or microstrip lines; for example to achieve greater accuracy or to remove known imperfections in a test setup, we can choose instead to de-embed the interface networks on each measurement port. The PicoVNA 2 software simply requires a full Touchstone .s2p file for the embedded interfacing network on each port. Likewise, defined networks can be embedded into the measurement to achieve a desired simulated measurement. As for a calibration, best accuracy will be achieved when the embedding network is defined at the same frequency points as the intended measurement. Unusually for a vector network analyzer, the PicoVNA 2 software will interpolate where necessary and possible.

Z_0 impedance reference

System measurement impedance (default 50 Ω) can be mathematically converted to any value between 10 Ω and 200 Ω . The PicoVNA 2 software also supports the use of external matching pads and calibration in the new impedance using a calibration kit of that impedance.

Time domain transmission and reflectometry measurements

Time domain reflectometry is useful in the measurement of a transmission line; in particular the distance-to-fault location of any discontinuity due to connectors, damage or design error. To achieve this, the PicoVNA 2 software determines from its frequency domain measurements the time domain response to a step input. Using a sweep of harmonically related frequencies, an inverse fast Fourier transform of reflected frequency data (S_{11}) gives the impulse response in the time domain. The impulse response is then integrated to give the step response. Reflected components of the step, occurring at measurable delays after excitation, indicate the type of discontinuity and (assuming a known velocity of propagation) the distance from the calibration plane.

A similar technique is used to derive a TDT (time domain transmission) signal from the transmitted signal data (S_{21}). This can be used to measure the pulse response or transition time of amplifiers, filters and other networks.

The PicoVNA 2 software supports Hanning and Kaiser–Bessel lowpass filtering on its time-domain IFFT conversions, preserving magnitude and phase, and achieving best resolution. A DC-coupled DUT is essential to the method.

P1dB utility

The 1 dB gain compression point of amplifiers and other active devices can be measured using a power sweep, either at a test frequency or over a sweep of test frequencies. The VNA determines the small-signal gain of the amplifier at low input power, and then increases the power and notes the point at which the gain has fallen by 1 dB. This utility uses a second-order curve fit to determine interpolated 1 dB compression points.

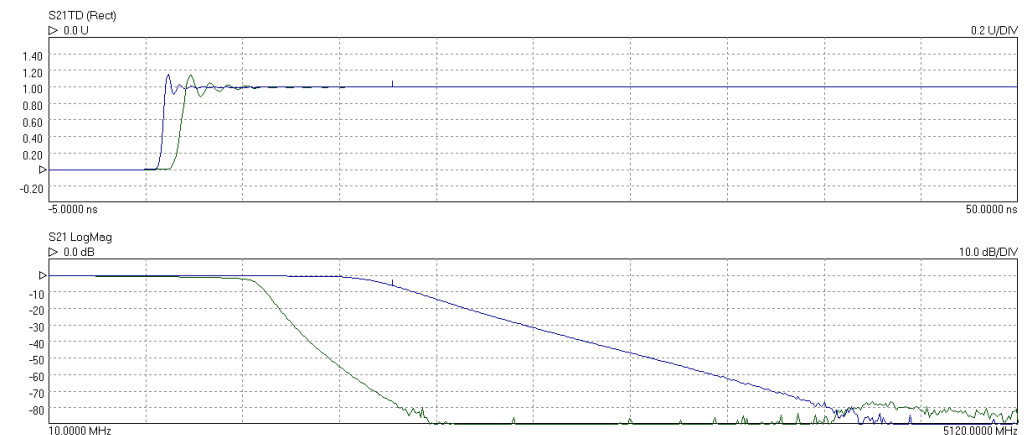

Time domain transmission step responses (top) and frequency responses (bottom) of two lowpass filters

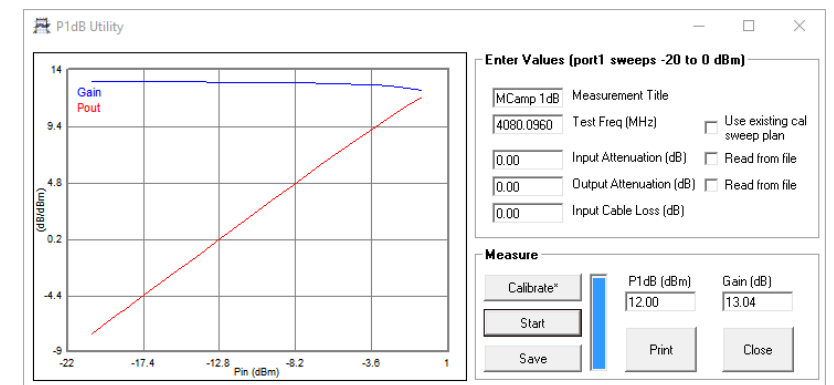

AM to PM conversion utility

AM to PM conversion is a form of signal distortion where changes in the amplitude of a signal produce corresponding changes in the phase of the signal. This type of distortion can have serious impact in digital modulation schemes for which amplitude varies and phase accuracy is important.

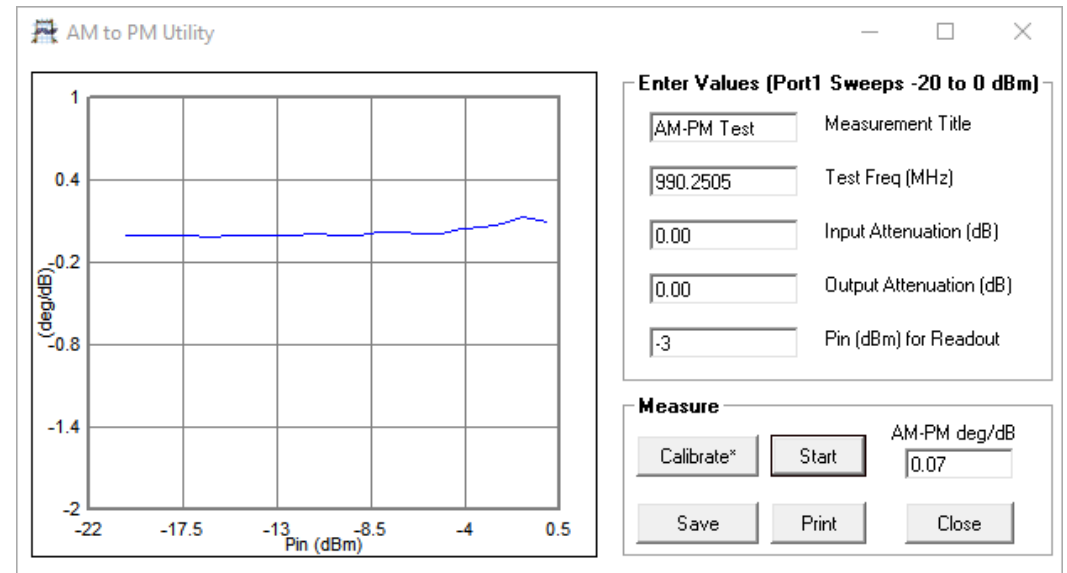

Limit lines testing

The limit lines facility allows six segments to be defined for each displayed plot. These can be extended to 11 segments using an overlapping technique. Visual and audible alarms can be given when a limit line is crossed. All plot formats except Smith chart and polar support limit testing. Peak hold functions are also available.

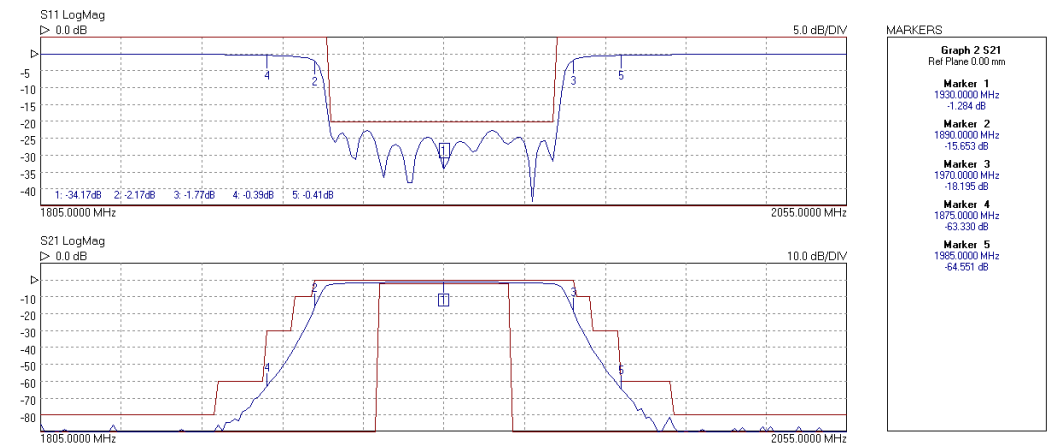

Specifications

Standard conditions: 10 Hz resolution bandwidth, at -3 dBm test power, at an ambient temperature of between 20°C and 30°C but within 1°C of the calibration temperature and 60 minutes after power-up.

Receiver characteristics

Parameter	Value	Conditions												
Measurement bandwidth	140 kHz, 70 kHz, 35 kHz, 15 kHz, 10 kHz, 5 kHz, 1 kHz, 500 Hz, 100 Hz, 50 Hz, 10 Hz													
Average displayed noise floor	<table border="1"> <thead> <tr> <th>Band (MHz)</th> <th>Typical (dB)</th> <th>Max. (dB)</th> </tr> </thead> <tbody> <tr> <td>0.3 – 10</td> <td>-110</td> <td>-100</td> </tr> <tr> <td>10 – 4000</td> <td>-118</td> <td>-108</td> </tr> <tr> <td>> 4000</td> <td>-110</td> <td>-100</td> </tr> </tbody> </table>	Band (MHz)	Typical (dB)	Max. (dB)	0.3 – 10	-110	-100	10 – 4000	-118	-108	> 4000	-110	-100	<p>Relative to the test signal level set to maximum power after an S_{21} calibration. Ports terminated as during the isolation calibration step.</p> <p>10 Hz bandwidth Maximum (+6 dBm) test power No averaging</p>
Band (MHz)	Typical (dB)	Max. (dB)												
0.3 – 10	-110	-100												
10 – 4000	-118	-108												
> 4000	-110	-100												
Dynamic range	See graphs (typical, excludes crosstalk)													

Dynamic range 0.3 MHz to 10 MHz

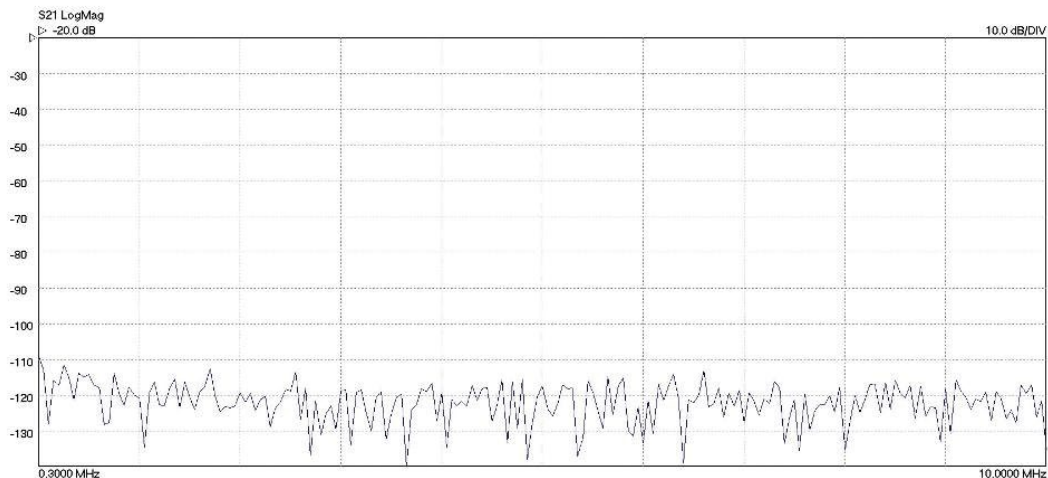

Dynamic range 10 MHz to 6 GHz

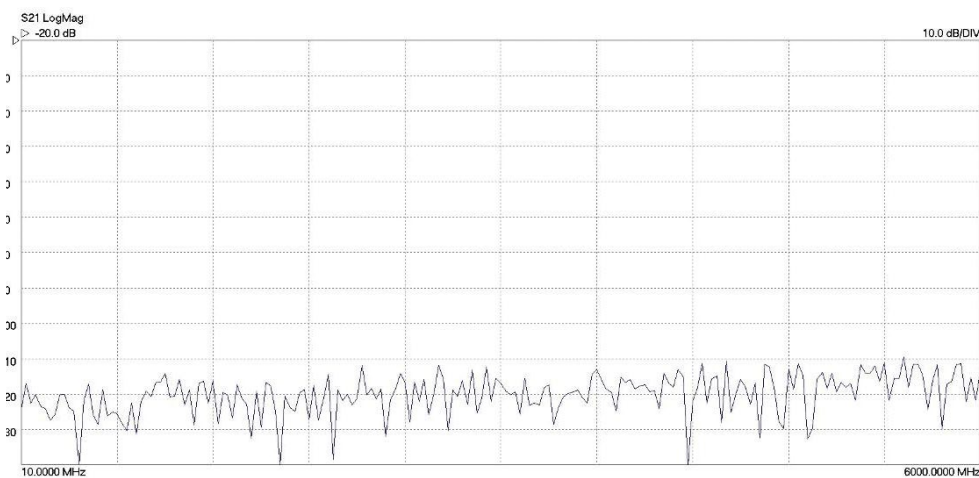

Temperature stability, typical

0.02 dB/°C for $F < 4$ GHz
0.04 dB/°C for $F \geq 4$ GHz

Measured after an S_{21} calibration

Trace noise (RMS)

Bandwidth (kHz)	Typical (dB)	Max. (dB)
10	0.0008	0.002
70	0.003	0.005
140	0.005	0.01

201-point sweep covering 1 MHz to 6 GHz.
Test power set to 0 dBm.

	Reflection measurements			Transmission measurements		
	Freq. range	Magnitude	Phase	Freq. range	Magnitude	Phase
Measurement uncertainty	-15 dB to 0 dB			+0 dBm to +6 dBm		
	< 2 MHz	0.7	8°	< 2 MHz	0.4	6°
	> 2 MHz	0.5	4°	> 2 MHz	0.2	2°
	-25 dB to -15 dB			-40 dBm to 0 dBm		
	< 2 MHz	0.8	10°	< 2 MHz	0.2	2°
	> 2 MHz	1.0	6°	> 2 MHz	0.1	1°
	-30 dB to -25 dB			-60 dBm to -40 dBm		
	< 2 MHz	3.0	20°	< 2 MHz	0.5	8°
	> 2 MHz	2.5	15°	> 2 MHz	0.3	4°
				-80 dBm to -60 dBm		
			< 2 MHz	2.0	15°	
			> 2 MHz	1.5	12°	

Test level of -3 dBm
 No averaging
 Bandwidth 10 Hz
 Ambient temperature equal to the calibration temperature.
 A 12 error term calibration is assumed carried out with a good quality 3.5 mm calibration kit capable of achieving the performance specified.

Spurious responses -76 dBc typical, -70 dBc max.

The main spurious response occurs at close to $(2 \times RF + 1.3)$ MHz, where RF is the test frequency in MHz. For example, when testing a bandpass filter with a centre frequency of, say 1900 MHz, an unwanted response will occur around 949.35 MHz. There may also be spurious responses close to $(3 \times RF + 2.6)$ MHz. In all known cases the levels will be as stated.

Test port characteristics

Load match	Uncorrected: 16 dB, typical Corrected: 46 dB, typical 40 dB, min	
Source match	Uncorrected: 16 dB, typical Corrected: 46 dB, typical 40 dB, min	
Directivity	Corrected: 47 dB, typical 40 dB, min	
Crosstalk	Band (MHz) Typical (dB) Max. (dB) < 2 -100 -90 2 to 4000 -110 -90 4000 to 6000 -100 -90	Corrected. Both calibrated ports terminated in short circuits. After isolation calibration.
Maximum input level	+10 dBm, typ	1 dB compression
Maximum input level	+20 dBm	No damage
Impedance	50 Ω	
Connectors	Type N, female	

Calibration kits

Device	PC3.5(f)	PC3.5(m)	SMA(f)*	SMA(m)*	Frequency (GHz)	* SMA calibration kits are calibrated in a PC3.5 reference system.
Load						
Uncorrected return loss	≥ 30 dB ≥ 27 dB	≥ 30 dB ≥ 26 dB	≥ 30 dB ≥ 26 dB	≥ 28 dB ≥ 26 dB	≤ 3 > 3	
Corrected return loss	≥ 46 dB ≥ 43 dB	≥ 46 dB ≥ 43 dB	≥ 40 dB ≥ 37 dB	≥ 40 dB ≥ 37 dB	≤ 3 > 3	Inferred from directivity after applying correction using measured data provided with the kit
Open circuit						
Return loss		≤ 0.15 dB ≤ 0.2 dB			≤ 3 > 3	
Short circuit						
Return loss		≤ 0.2 dB ≤ 0.25 dB			≤ 3 > 3	
Through adaptor						
Insertion loss	≤ 0.15 dB	≤ 0.15 dB	≤ 0.15 dB	≤ 0.2 dB	≤ 6 GHz	
Transfer calibration method	SOLT comparison TRL comparison		SOLT comparison		300 kHz to 1.5 GHz 1.5 GHz to 6 GHz	SOLT = short, open, load, through TRL = through, reflect, line

Bias-T input characteristics

Maximum current	250 mA					
Maximum DC voltage	±15 V					
Current protection	Built-in resettable fuse					
DC port connectors	SMB(m)					

Sweep I/O characteristics

Sweep trigger output voltage	Low: 0 V to 0.8 V High: 2.2 V to 3.6 V					
Sweep trigger input voltage	Low: -0.1 V to 1 V High: 2.0 V to 4 V					
Sweep trigger input voltage	±6 V					No damage
Sweep trigger in/out connectors	BNC female on back panel					

Measuring functions

Measuring parameters	$S_{11}, S_{21}, S_{22}, S_{12}$ P1dB (1 dB gain compression) AM to PM conversion factor (PM due to AM)
Error correction	12 error term full S-parameter correction (insertable DUT) 12 error term full S-parameter correction (non-insertable DUT) 8 error term full S-parameter unknown through correction (non-insertable DUT) S_{11} (1-port correction) De-embed (2 embedding networks may be specified) Impedance conversion S_{21} (normalize, normalize + isolation) S_{21} (source match correction + normalize + isolation) Averaging, smoothing Hanning and Kaiser–Bessel filtering on time-domain measurements Electrical length compensation (manual or auto) Effective dielectric constant correction
Display channels	4 channels
Traces	2 traces per display channel
Display formats	Amplitude (logarithmic and linear), phase, group delay, VSWR, real, imaginary, Smith chart, polar, time domain
Memory trace	One per display channel
Limit lines	6 segments per channel (overlap allowed)
Markers	8 markers
Marker functions	Normal, Δ marker, fixed marker, peak / min. hold, 3 dB and 6 dB bandwidth

Sweep functions

Sweep type	Linear sweep CW sweep (timed sweep) Power sweep (P1dB utility)			
Sweep times	Bandwidth	S_{21} cal	12-term cal	10 MHz to 6 GHz, 201 point sweep. For other trace lengths and resolution bandwidths the sweep time is approximately: $T_{SWP} = N \times (T_{MIN} + F_{BW} / R_{BW}) + T_{ARM}$ where: N = number of frequency points T_{MIN} = minimum time / point (s2p: 169 μ s; s1p: 115 μ s) F_{BW} = bandwidth settle factor (s2p: 2.81; s1p: 1.425) R_{BW} = resolution bandwidth (Hz) For sweep repetition period add rearm time (average 9.5 ms or maximum 17.5 ms)
	140 kHz	25 ms	37 ms	
	10 kHz	52 ms	88 ms	
	1 kHz	306 ms	0.6 s	
	100 Hz	2.85 s	5.5 s	
	10 Hz	28.5 s	57 s	
Number of sweep points, VNA mode	51, 101, 201, 401, 801, 1001, 2001, 4001, 5001, 6001, 7001, 8001, 9001, 10001			
Number of sweep points, TD mode	512, 1024, 2048, 4096			

Signal source characteristics

Frequency range	300 kHz to 6.0 GHz	
Frequency setting resolution	10 Hz	
Frequency accuracy	10 ppm max	With ambient of 23 ±3 °C
Frequency temperature stability	±0.5 ppm/°C max	Over the range +15 °C to +35 °C
Harmonics	-20 dBc max	With test power set to < -3 dBm
Non-harmonic spurious	-40 dBc typical	
Phase noise (10 kHz offset)	0.3 MHz to 1 GHz: -90 dBc/Hz 1 GHz to 4 GHz: -80 dBc/Hz > 4 GHz: -76 dBc/Hz	
Test signal power	< 10 MHz: -3 to -20 dBm 10 MHz to 4 GHz: +6 to -20 dBm > 4 GHz: +3 to -20 dBm	
Power setting resolution	0.1 dB	
Power setting accuracy	±1.5 dB	
Reference input frequency	10 MHz ±6 ppm	
Reference input level	0 ±3 dBm	
Reference output level	0 ±3 dBm	

Miscellaneous

Controlling PC data interface	USB 2.0
Support for third party test software	Dynamic Link Library (DLL) as part of user interface software
External dimensions (mm)	286 x 174 x 61 (L x W x H) excluding connectors
Weight	1.85 kg
Temperature range (operating)	5 °C to 40 °C
Temperature range (storage)	-20 °C to +50 °C
Humidity	80% max, non-condensing
Vibration (storage)	0.5 g, 5 Hz to 300 Hz
Power source and current	+12 to +15 V DC, 22 W
Power source connector	5.5 mm diameter hole, 2.1 mm diameter centre contact pin. Centre pin is positive.
Host PC requirements	Microsoft Windows 7, 8 or 10 2 GB RAM or more
Safety	Conforms to EN61010-1:2010 and EN61010-2-030:2010
Warranty	3 years

PicoVNA 106 kit (PQ111) contents

PicoVNA 106 6 GHz vector network analyzer



PS010 Universal input 12 V 4.5 A output power supply



PicoVNA 106 carry case



PicoVNA 2 software and documents on USB flash drive



TA359 Adjustable connector wrench



TA177 SMA M8 combination wrench



MI106 Pico blue USB 2.0 cable 1.8 m



Available separately

TA356 Dual-break torque wrench SMA / PC3.5 / K-type,
1 N·m / 8.85 in·lb



TA358 Dual-break torque wrench N-type 1 N·m / 8.85 in·lb



Ordering information

Order code	Description	USD*	EUR*	GBP*
PQ111	PicoVNA 106 6 GHz vector network analyzer	5995	5085	4205
TA336	Standard 6 GHz flexible test lead, male port, N(m)-SMA(m)	279	239	199
TA337	Standard 6 GHz flexible test lead, female port, N(m)-SMA(f)	279	239	199
TA338	Premium 6 GHz flexible test lead, male port, N(m)-PC3.5(m)	749	639	529
TA339	Premium 6 GHz flexible test lead, female port, N(m)-PC3.5(f)	749	639	529
TA342	ADA-STD-MM Standard test port adaptor SMA(m-m)	74	60	49
TA343	ADA-STD-FF Standard test port adaptor SMA(f-f)	74	60	49
TA357	ADA-STD-FM Standard within series adaptor SMA(f-m)	74	60	49
TA340	ADA-PREM-MM Premium test port adaptor PC3.5(m-m)	139	119	99
TA341	ADA-PREM-FF Premium test port adaptor PC3.5(f-f)	139	119	99
TA354	ADA-PREM-FM Premium within series adaptor PC3.5(f-m)	139	119	99
TA344	SOLT-STD-M Standard 6 GHz SOLT calibration kit, SMA(m)	449	389	319
TA345	SOLT-STD-F Standard 6 GHz SOLT calibration kit, SMA(f)	449	389	319

Order code	Description	USD*	EUR*	GBP*
TA346	SOLT-PREM-M Premium 6 GHz SOLT calibration kit, PC3.5(m)	749	639	529
TA347	SOLT-PREM-F Premium 6 GHz SOLT calibration kit, PC3.5(f)	749	639	529
MI030	BNC-BNC cable 1 m	14	12	9
TA170	Adaptor 18 GHz 50 Ω SMA(m-f)	20	18	14
TA314	Adaptor 18 GHz 50 Ω SMA(f)-N(m)	119	99	81
TA262	Attenuator 10 dB 10 GHz 50 Ω SMA(m-f)	75	67	53
TA173	Attenuator 20 dB 10 GHz 50 Ω SMA(m-f)	75	67	53
TA181	Attenuator 3 dB 10 GHz 50 Ω SMA(m-f)	75	67	53
TA261	Attenuator 6 dB 10 GHz 50 Ω SMA(m-f)	75	67	53
TA265	Precision sleeved coaxial cable 30 cm 1.3 dB @ 13 GHz	65	58	46
TA312	Precision sleeved coaxial cable 60 cm 2.2 dB @ 13 GHz	70	59	47
TA358	Dual-break torque wrench N-type 1 N·m / 8.85 in·lb	199	169	139
TA356	Dual-break torque wrench SMA / PC3.5 / K-type, 1 N·m / 8.85 in·lb	199	169	139
CC046	PicoVNA 106 calibration certificate and data	349	299	249
CC047	SOLT-STD-M or SOLT-STD-F calibration	99	84	69
CC048	SOLT-PREM-M or SOLT-PREM-F calibration	139	119	99

UK global headquarters:

Pico Technology
James House
Colmworth Business Park
St. Neots
Cambridgeshire
PE19 8YP
United Kingdom
☎ +44 (0) 1480 396 395
☎ +44 (0) 1480 396 296
✉ sales@picotech.com

North America regional office:

Pico Technology
320 N Glenwood Blvd
Tyler
Texas 75702
United States
☎ +1 800 591 2796
☎ +1 620 272 0981
✉ sales@picotech.com

Asia-Pacific regional office:

Pico Technology
Room 2252, 22/F, Centro
568 Hengfeng Road
Zhabei District
Shanghai 200070
PR China
☎ +86 21 2226-5152
✉ pico.china@picotech.com

* Prices correct at the time of publication. Sales taxes not included. Please check www.picotech.com for the latest prices before ordering. Errors and omissions excepted. *Pico Technology* is an internationally registered trade mark of Pico Technology Ltd. *PicoVNA* is a trade mark of Pico Technology Ltd.

MM084.en-4. Copyright © 2017–2018 Pico Technology Ltd. All rights reserved.



www.picotech.com