

A reliable, fully remote-controlled Multipoint Sampler for gas sampling of up to 24 different locations

INNOVA 1409

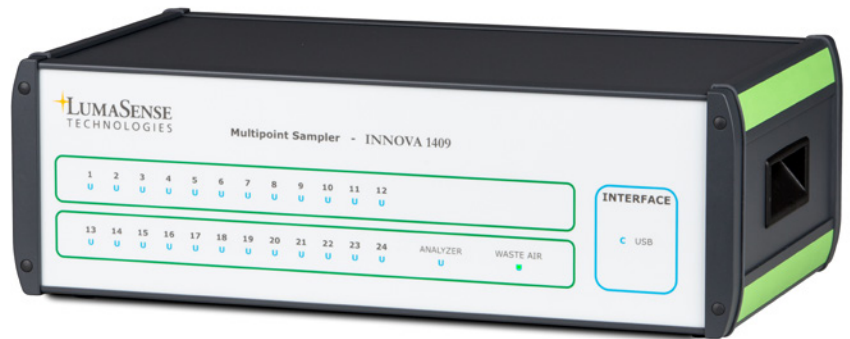

- Full remote control over the USB interface: the system controller can either be the gas monitor or an online PC
- 6 to 24 sample input channels depending on the configuration
- Self-test function
- Pneumatic system constructed of AISI-316 Stainless Steel and PTFE tubing to minimize gas adsorption
- Integrates seamlessly with the INNOVA Photoacoustic Gas Monitors
- LED indicators for active channel and interface



The INNOVA 1409 Multipoint Sampler from LumaSense Technologies is designed to extend the capabilities of LumaSense gas monitors. The 1409 is delivered as a 6, 12, or 24 channel Multipoint Sampler, enabling gas samples to be drawn from up to 24 different sampling locations and delivered to the gas monitor.

The sampling system is configured from the system controller: either directly via the front panel interface of the gas monitor, or using one of the available softwares (BZ7007 or LumaSoft 7870). The 1409 communicates with the gas monitor over a USB interface. When using LumaSoft 7870 as a system controller, the computer is connected to the gas monitor via the RS232 serial, USB, or Ethernet interface.

Description and Functions

The pneumatic system of the 1409 is shown in Fig.1. The sampler system is constructed of AISI-316 stainless steel

and PTFE (poly-tetrafluoroethylene) tubing to minimize adsorption of samples. The system has 6 to 24 inlet channels depending on the configuration. Each inlet channel has a tube-mounting stub on the backplate of the 1409; to connect each channel to the respective sampling point. The 24 inlet channels converge into one; a three-way valve then directs the gas sample to the gas monitor for analysis, or through the external pump (optional) via the waste-air outlet on the 1409's backplate.

The highly efficient 1409's sampler system transports gas samples from the sampling point at approximately four meters per second. This speed depends on the type of pump, the diameter of the tubing, and the length of tubing attached to the 1409. An air filter is attached to the end of each sampling tube to keep the 1409 free of particles.

Reliability

Reliability is ensured by automatic self-tests of both hardware and software. The 1409's operating status can be read-out at any time.

Application Areas:

- **Occupational Safety & Health Area monitoring:**
Air sampling in up to 24 locations and delivery of the sample to an INNOVA photoacoustic monitor.
- **Leak monitoring:**
Sampling air with good spatial distribution (up to 24 sampling points) across large enclosed rooms, and delivering the sample to a central monitor unit.
- **Multipoint gas analysis:**
Parallel processing of multiple gas cells or chambers with a unique monitor.

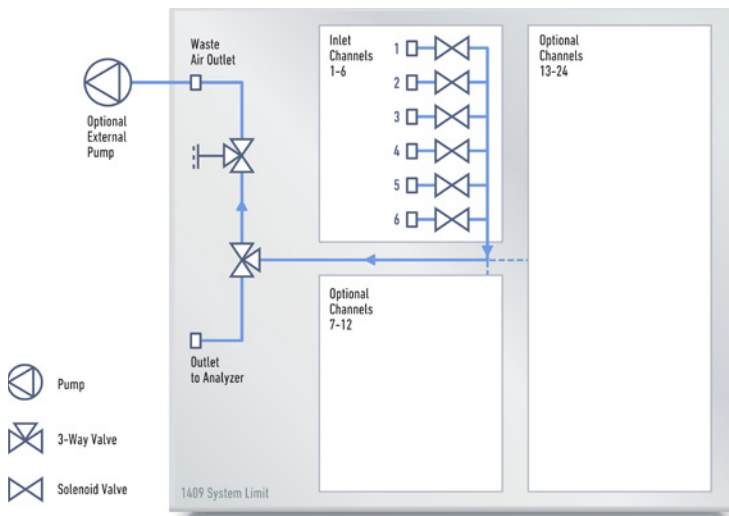

Fig. 1. A schematic diagram of the 1409's pneumatic system. The use of non-reactive materials throughout minimizes gas adsorption in the internal air-channels.



Fig. 1 bis. View of the back panel for the 1409-24 Multipoint Sampler. Plug and play design for a seamless integration with the INNOVA Photoacoustic Gas Monitors.

Control of the 1409

The 1409 is remotely controlled either by using the gas monitor as a system controller (the monitoring/sampling system then operates in standalone mode), or by LumaSoft 7870 Multipoint Software running on a computer connected to the gas monitor and communicating over the RS232, USB, or Ethernet interface.

Commands and information requests are sent over the USB interface to the 1409 to control the sampler system and to read-out data.

System Use

The 1409 combined with a gas monitor offers wide-ranging monitoring capabilities. The 1409 makes it possible to perform multipoint monitoring tasks in a variety of situations and environments, without changing the system components.

An example of a multipoint, multigas monitoring system is shown in Fig. 2. Air samples are drawn from up to 24 sampling points and delivered to the monitor. The monitor can then measure the concentrations of up to five gases, water vapor, and air pressure in each sample. With its design with a set of 3-way valves (see Fig. 1), the 1409 sampler can be equipped with an optional external pump: while the gas monitor analyzes

the active channel, the system can already sample gas from the next channel in the sequence order.

Setting Up the Sampling Task

The selection of the active channels can be done either directly via the front panel interface of the gas monitor, or using one of the available softwares (7870 and BZ7007). Furthermore the 7870 software enables to customize the sampling sequence across the active channels.

Standalone Multipoint Monitoring

INNOVA Photoacoustics Gas Monitors (1314i, 1412i, and 3434i) can be setup as a system controller. Their internal CPU is then synchronizing the sampling and gas measurement tasks; it stores the measurement readings in the internal memory on a gas per gas basis, and across the active sampling channels.

Online Multipoint Monitoring

The LumaSoft Gas Multipoint 7870 software offers full coordination and control of all the sampling and monitoring functions of the system. The software coordinates the functions of the instruments to form a monitoring system which, via tubing, can perform gas-monitoring tasks in up to 24 different locations.

When a user sets up a measurement task using the software, the task is performed automatically and

measurement data is collected and displayed on the screen.

Measurement data is stored in an SQL Server 2005 database, providing easy access to measurement data during a measurement task. The user also has online access to measurement data from Microsoft Excel while a task is running. This makes the data readily available to produce tailor-made reports.

Alarm Features

When operating in online multipoint monitoring with LumaSoft 7870, software alarms can be defined for each gas on each channel.

In standalone operation with the 1314i Photoacoustic Monitor, alarm relays can be configured as an option, either for each gas on any channel or for selected channels on any gas.

1409 Configurations

The 1409 is delivered in three different configurations.

- 1409-6: With 6 channels
- 1409-12: with 12 channels
- 1409-24: with 24 channels

Rack Version

The 1409 can be delivered as a rack version by adding the Flange Panel for Rack mount.

Online Multipoint Monitoring

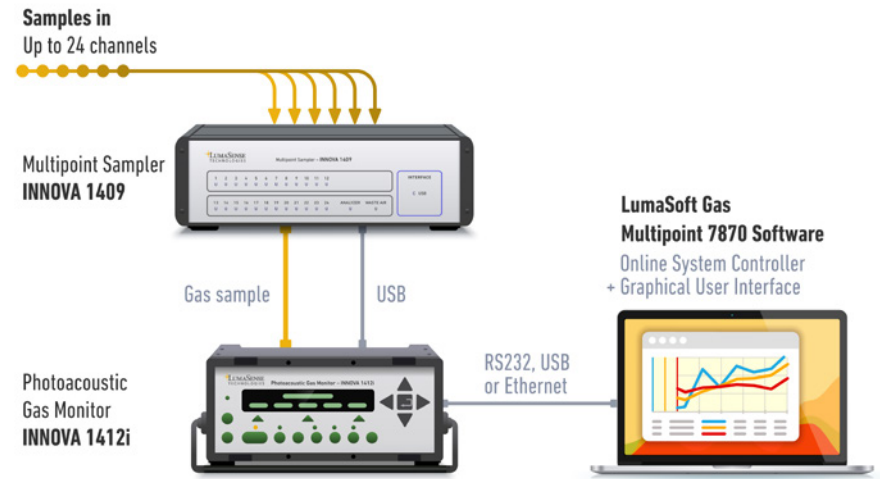

Fig. 2. The 1409 Multipoint Sampler unit is connected to one INNOVA Photoacoustic Gas Monitor via USB interface. The system (Sampler + Monitor) is controlled remotely by the LumaSoft Gas Multipoint 7870 software from a PC which can connect to the gas monitor via RS232, USB, or Ethernet. The software provides online monitoring features, including a real-time display of the data.

Standalone Multipoint Monitoring

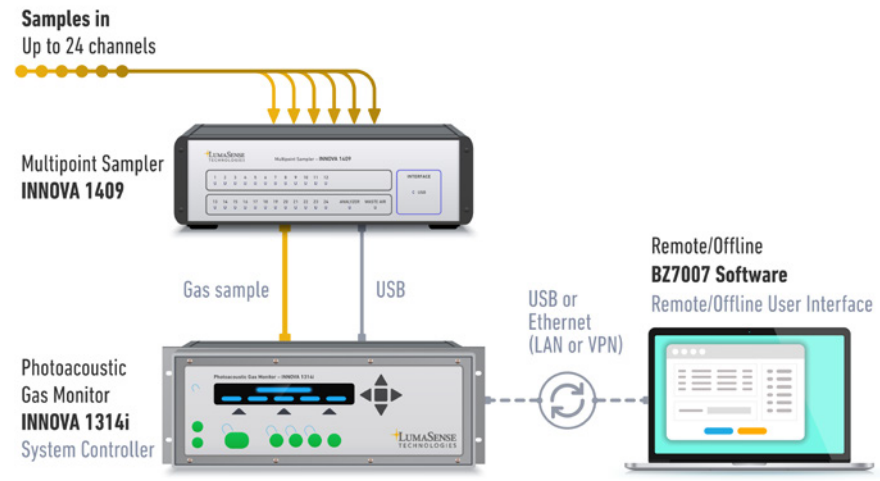

Fig. 2.bis. The 1409 Multipoint Sampler unit is connected to one INNOVA Photoacoustic Gas Monitor via USB interface. The gas monitor is the system controller for this standalone multipoint monitoring system. The BZ7007 software is a remote and offline user interface which can be used to configure the system (including an optional alarm relay module for the INNOVA 1314i), or to connect upon need to the system and retrieve the measurement log from the monitor internal memory.

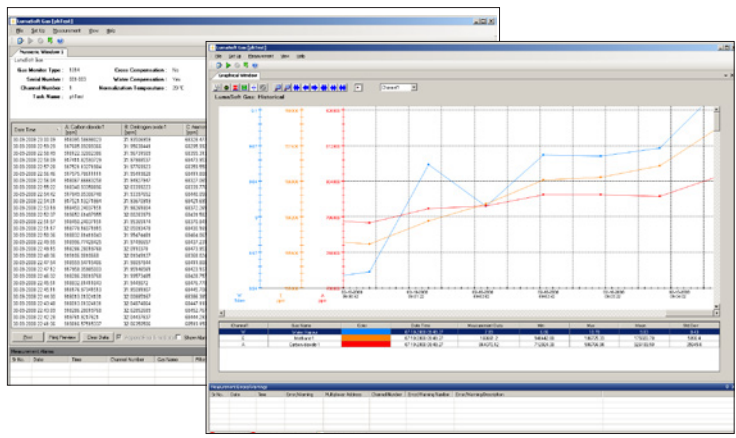

Fig. 3. With LumaSoft 7870, the systems operates in online mode with numeric and graphic windows showing the measurement values and other appropriate information for each sample channel and each gas in real time.

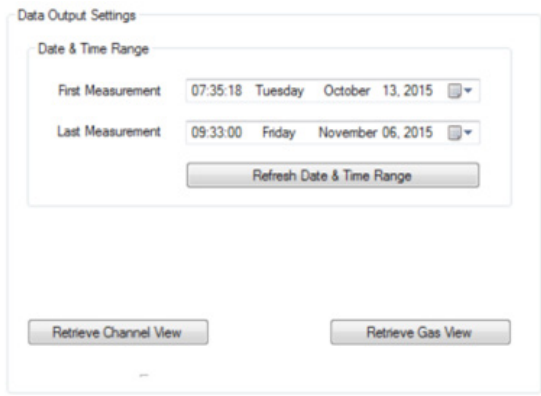

Fig. 4. When the gas monitor and the 1409 Multipoint Sampler run as a standalone system, the Remote/Offline software (BZ7007) can be used to retrieve the measurement log from the monitor's memory and then export it in MS Excel format.

Technical Specifications

WARNING!

The 1409 must not be placed in areas with flammable gases/vapors in explosive concentrations, or be used for tasks in which explosive concentrations of these gases/vapors are monitored. Also note that certain aggressive gases could damage the internal airways of the 1409. Ask your LumaSense representative for further information.

Pump Performance

Two external pumps are available:

Pump	Distance	TubeØ	Speed
Small	0 - 75 m	3 mm	4 m/s
Large	75 -150 m	4 mm	5 m/s

For tube lengths up to 300 m a pump must be placed in front of each sampling channel.

USB Interface

USB 2.0 Standard

Power Supply

Voltage: 100 – 240 VAC 50/60 Hz
Power consumption: 0.4 A

Dimensions

Height: 155 mm (6.10 inch)
Width: 445 mm (17.5 inch)
Depth: 260 mm (10.2 inch)

Weight

Depending on the configuration:

- 1409-6: with 6 channels
6.6 kg (14.6 lbs.)
- 1409-12: with 12 channels
7.9 kg (17.4 lbs.)
- 1409-24: with 24 channels
10.3 kg (22.7 lbs.)

	COMPLIANCE WITH STANDARDS: CE-mark indicates compliance with: EMC Directive and Low Voltage Directive.
Safety	EN 61010-1 3rd Ed. (2010): Safety requirements for electrical equipment for measurement, control and laboratory use.
EMC Emission	EN 61326-1:2013: Electrical equipment for measurement, control and laboratory use - EMC requirements - Part 1: General requirements
Environment	IEC 61010-1: Environmental conditions. Altitude up to 2000 m Operating Temperature: +5 °C to +40 °C Storage Temperature: -25 °C to +55 °C Humidity: Maximum relative humidity 80% for temperatures up to 31 °C decreasing linearly to 50% relative humidity at 40 °C Pollution Degree 2 Installation category II Indoor Use
Enclosure	IP40

Ordering Information

1409 Multipoint Sampler

Includes the following accessories:

3xYM0652 Knurled nuts to secure tubing to nozzles
AS0001 USB interface cable
BZ7007 Remote/Offline Software

Mains cable

Instruction Manual

Optional Accessories

7870 LumaSoft Gas Multi Point Software
EB6000 External pump (small), 230V
EB6004 External pump (small), 115V
EB6002 External pump (large), 230 V
EB6003 External pump (large), 115 V
AF0614 PTFE tubing
AF0007 Nylon tubing

UD5023 External air-filter
DS0759 Filters (25) for air-filter unit (UD5023)
UA1365 In line Genie Membrane Separator
DS6015 Membrane replacements (5) for UA1365
EH6039 6 Channel Nozzle Modification Kit (to use 4mm tubing with the 1409).
KS0160 Flange Panel for 19" rack mount

LumaSense Technologies

Americas, Australia, India, China
Sales & Service
Santa Clara, CA
Tel: +1 800 631 0176
Fax: +1 408 727 1677

info@lumasenseinc.com

LumaSense Technologies, Inc., reserves the right to change the information in this publication at any time.

Europe, Middle East, Africa
Sales & Service
Frankfurt, Germany
Tel: +49 69 97373 0
Fax: +49 69 97373 1677

Awakening Your 6th Sense

INNOVA Gas Products Sales & Service
LumaSense Technologies A/S
Energivej 30, DK- 2750 Ballerup
Tel:+45 44 20 01 00
Fax:+45 44 20 01 01

www.lumasenseinc.com

©2017 LumaSense Technologies. All rights reserved.
Innova-1409_Datasheet-EN - Rev. 05/22/2017