

LumaSpection™ Infrared Camera System for Continuous Reformer Tube Monitoring and Temperature Measurement Inside Furnaces in Refining, Glass, and Metal Processes

FurnaceSpection™

- Rugged IP66, air cooled, protective enclosure
- Accurate 640 x 480 focal-plane array thermal imaging camera with sensitivity of 0.06 °C
- Ethernet interface for long distance reliable communication
- Boroscope optics filtered at 0.85 μm wavelength to view through combustion gas and flames
- Auto retraction for SD systems
- Class 1 Div 2 compliant
- Advanced software with simultaneous acquisition from multiple cameras, advanced analysis tools, support for OPC, analog and digital IOs, web service, and archiving
- Complete system integration with installation support

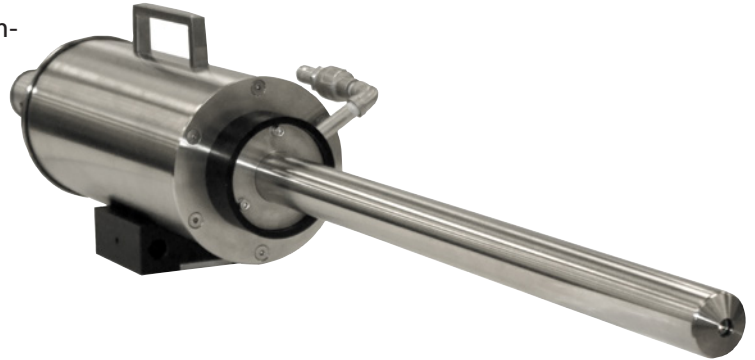

This LumaSpection™ system is designed and developed for continuous temperature measurement inside high temperature furnaces in refining, metals, and glass production. FurnaceSpection's proven technology provides critical insight for failure prevention and asset management.

The FurnaceSpection™ imager provides users with a real-time tool for quickly and accurately identifying process abnormalities before they develop into problems that can lead to unplanned outages. This radiometrically calibrated imager accurately measures the temperature of product, refractory, and heat transfer surfaces inside natural gas fired furnaces. In addition to both standard (SD) and mobile (MB) versions, we can customize a solution to meet your application needs.

For petrochemical reformers, this is a critical tool to ensure tubes perform optimally for their longest possible life cycle. At a cost of several thousands of dollars per tube and a re-tubing costs in the millions, a significant amount of

capital can be lost if tube failure goes unnoticed or tubes are retired too early or too late.

In metal annealing applications, FurnaceSpection™ cameras have allowed users to reduce cycle times while at the same time improving quality and process repeatability.

FurnaceSpection™ helps operators monitor and control process temperature uniformity through streaming images and powerful software for analysis and historical trending. Digital and Analog outputs are available to broadcast images of the plant's local network.

Lumasense has been developing industrial grade thermal imaging solutions for over 20 years, and have deployed custom systems around the globe to monitor critical processes and assets in power generation, refineries, steel, paper, and glass plants. Our products are supported by experienced field service and application engineering team.

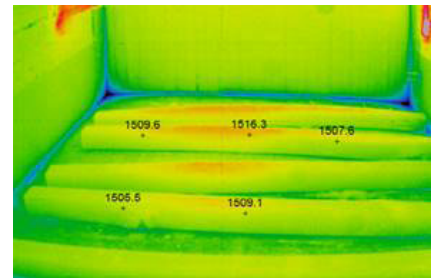

Image of furnace with temp points



Infrared image of inside furnace



FurnaceSpection system setup

Technical Data

IR Camera

Wavelength	Narrowband 850 nm
Resolution	640 x 480
Detector Type	Silicon based
Acquisition Speed	60 fps (60 Hz)
Protective Housing	IP66 with air cooling
Measurement Range	600 to 1800 °C
Ambient Environment	Up to 140 °F (60 °C)
Camera Weight	23 lbs

Lens

Construction	Stainless steel with air cooling / purge
Field of View	50° H x 38° V
Focus	Manual
Protection	Sapphire window tip with air purge shield*
Diameter	Air cooled: 1.65" (42 mm)

Facility Connection Requirements

Power	110-240 VAC, two 15 Amp Lines to support six cameras
Electrical Cabinets	All cabinets/panels are NEMA 4 / IP65
Air Supply	15 cfm at 100 psi at the camera 20 cfm at 20 psi for the lens

Automatic Retraction Device and Mounting (for SD units)

Controls	Automated retraction if air or power is disrupted
Air Filters	Two stage filter system
Air Regulators	Included with filter
Mounting	Weld or bolt on mounting plates
Weld-on thru Hole	2.5" (64 mm)
Furnace Pressure	Negative, Balanced or Positive Pressure

Networking

Number of Cameras	Up to 10 with a single controller (at 1 fps)
Camera Connection	1000 Base T Ethernet
Field Switch Cabinet	NEMA 4 / IP65 enclosure with Ethernet Switch
Connection to Control Room	Fiber Optic Link, 50/125µm core/cladding diameter multi-mode fiber, 850/1310nm wavelength

FurnaceSpection Control Room Server/Software

Key Features	Simultaneous acquisition from multiple systems, automated image analysis, support for multiple regions of interest, auto archiving, OPC support, analog/digital IO support, and web server
Server	Single server controls up to 10 cameras (at 1 fps)

Reference Numbers

FurnaceSpection SD

912-0009-02	FurnaceSpection SD with Air Cooled Housing and Lens, 24" (61 cm) borescope lens, standard 50° FOV
112-0002-02	Wall Box for 24" Camera
812-0003-01	Auto Retraction Device with local controls, power supply for camera and stainless braided air lines
812-0002-01	Air Filtration System
112-0010-01	Standard SD wall mounting plate, Weld-On, 304 Stainless Steel
112-0003-01	Standard SD wall mounting plate, Bolt-On, 304 Stainless Steel

FurnaceSpection MB

012-0021-01	FurnaceSpection-MB system with 24" (61 cm) straight lens, standard 50° FOV
012-0021-02	FurnaceSpection-MB system with 24" (61 cm) angled 45° lens, standard 50° FOV
012-0021-03	FurnaceSpection-MB system with 24" (61 cm) angled 90° lens, standard 50° FOV
912-0055-01	Accessory Kit (Air Filtration, Hoses & Laptop)

Custom solutions are also available, please contact us for more information.

LumaSense Technologies

Awakening Your 6th Sense

**Americas and Australia
Sales & Service**
Santa Clara, CA
Ph: +1 800 631 0176
Fax: +1 408 727 1677

**Europe, Middle East, Africa
Sales & Service**
Frankfurt, Germany
Ph: +49 69 97373 0
Fax: +49 69 97373 167

**India
Sales & Support Center**
Mumbai, India
Ph: +91 22 67419203
Fax: +91 22 67419201

**China
Sales & Support Center**
Shanghai, China
Ph: +86 133 1182 7766
Ph: +86 21 5877 2383

info@lumasenseinc.com

LumaSense Technologies, Inc., reserves the right to change the information in this publication at any time.

www.lumasenseinc.com

©2016 LumaSense Technologies. All rights reserved.
FurnaceSpection-Datasheet-EN - Rev. 10/25/16